

Tram Chain

Tram chains are based on standard transmission chain construction but used in feeder applications on continuous mining machinery. The chains are operated in twin strand format with flight bars making the two strands common. Typical pitches are 2.00" (50.8 mm) and 2.50" (63.50 mm). Materials are enhanced to ensure higher strengths and wear resistance.

STYLE A

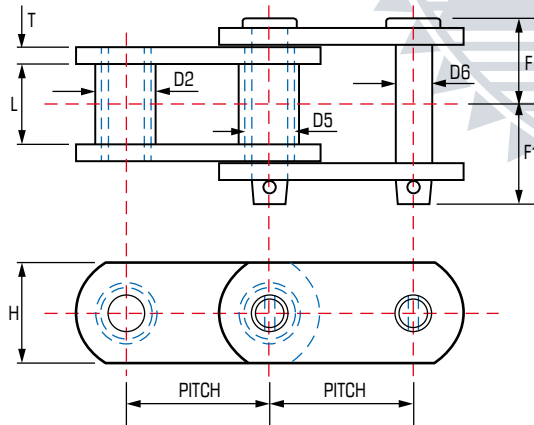

STYLE B

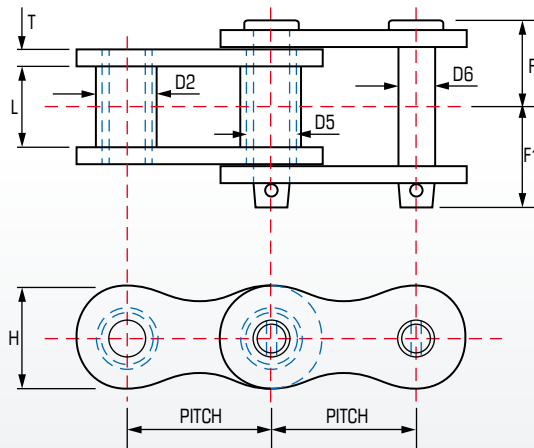

Tram Chains

Chain Number	Pitch inches	Style	Chain Width				Pins		Bushings		Rollers		Sidedbars			Approx. Weight lbs/ft
			Overall	Head to CL	End to CL	Inside Width	Diameter	Material	Diameter	Material	Diameter	Material	Thick-ness	Height	Material	
			F+F1	F	F1	L	D6		D5		D2		T	H		
JKM2	2.00	A	3.38	1.44	1.72	1.25	0.72	AHT	1.13	ACH	-	-	0.31	1.88	AHT	8.3
JKM645	2.50	B	3.72	1.69	2.00	1.50	0.88	AHT	1.13	ACH	1.56	AHT	0.38	2.13	AHT	13.5
JKM6414	2.50	B	4.13	1.91	2.00	1.50	0.88	AHT	1.13	ACH	1.56	AHT	0.44	2.13	AHT	14.5

Material AHT = alloy heat treated ACH = alloy case hardened.
JKM6414 sidebar thickness on roller links is .50" and pin link .44"
JKM2 is a bushing type chain and does not have rollers

Mining Chains

Engineering Class Shuttle Car Chain – Style JKR

Shuttle cars are designed to efficiently remove cut material from the mine work face in such a manner as to enhance the performance of continuous mining equipment in order to maximise productivity. Two standards styles are illustrated but this is not exhaustive, many bespoke types are available as special production.

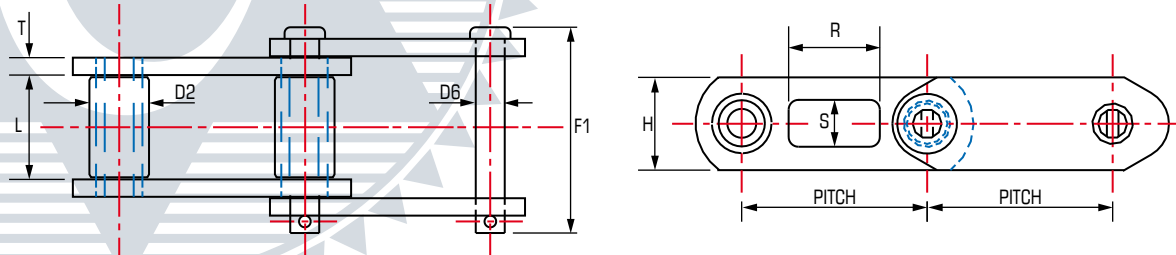

Engineering Class Shuttle Car Chain – Style JKR

Chain Number	Pitch inches	Spacing	Chain Width		Pins		Rollers		Sidedbars			Attachments		Approx. Weight lbs/ft
			Overall F1	Inside Width L	Diameter D6	HTC	Diameter D2	HTC	Thickness T	Height H	HTC	R	S	
			inches											
JKR2609/BM5X6	2.609	Ev. 6th	2.91	1.13	0.56	C	1.13	C	0.31	1.63	T	1.28	0.66	6.3
JKR2609/BM5X8	2.609	Ev. 8th	2.91	1.13	0.56	C	1.13	C	0.31	1.63	T	1.28	0.66	6.3
JKR3075/BM5X6	3.075	Ev. 6th	3.56	1.50	0.63	C	1.25	C	0.38	1.75	T	1.28	0.66	8.8

Heat Treatment code (HTC)

- T – Hardened and Tempered
- C – Case Hardened
- I – Induction Hardened

Combination Class Shuttle Car Chain

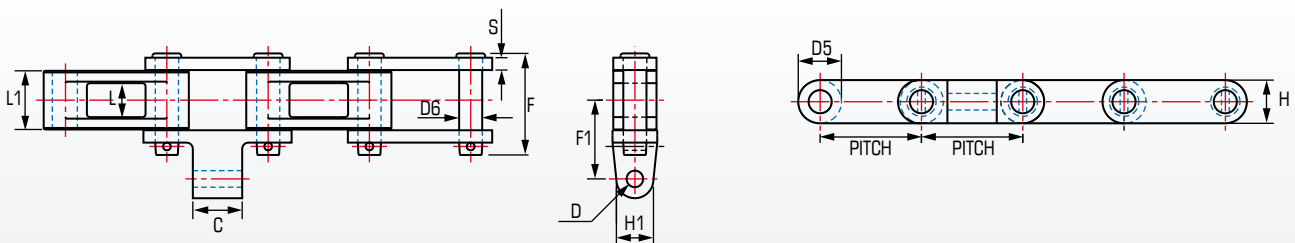

Combination Class Shuttle Car Chain

Chain Number	Pitch	Inner Width	L1	Bush Diameter	Plate Height	Plate Thickness	Pin Diameter	Pin Length	F1	H1	D	C	Average Ultimate Strength	Rated Working Load	Weight
		Max		Max	Max	Max	Max								
		L		D5	H	S	D6	F							
inches											lbs	lbs/ft			
D4100	4.100	1.375	2.375	1.750	1.750	0.500	0.940	4.110	3.970	1.500	0.670	2.000	105,000	7,750	11.40

Feeder Breaker Chain – Style JKB

Feeder breakers are primary crushers with pick mounted roll crushers combining with a chain conveyor. They are designed to act as first phase crushers of mined mineral including coal, limestone, potash, gypsum and PET coke down to a suitable size for continuous transport. They can be either mobile or static machines and employ a variety of "running gear".

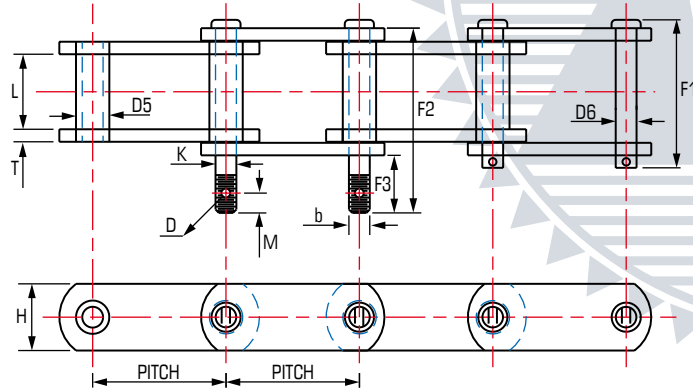

Feeder Breaker Chain – Style JKB

Chain Number	Pitch	Chain Width		Pins		Bushings		Sidedbars			Attachments						Approx. Weight lbs/ft
		Overall F1	Inside Width L	Diameter D6	HTC	Diameter D5	HTC	Thickness T	Height H	HTC	F3	F2	K	b	M	D	
JKB3075/D3X4	3.075	3.44	1.31	0.68	C	1.25	C	0.38	1.50	T	2.06	4.94	0.67	0.63	0.50	0.25	4.6

Heat Treatment code (HTC)

- T – Hardened and Tempered
- C – Case Hardened
- I – Induction Hardened

Engineering Class Feeder Breaker Chain

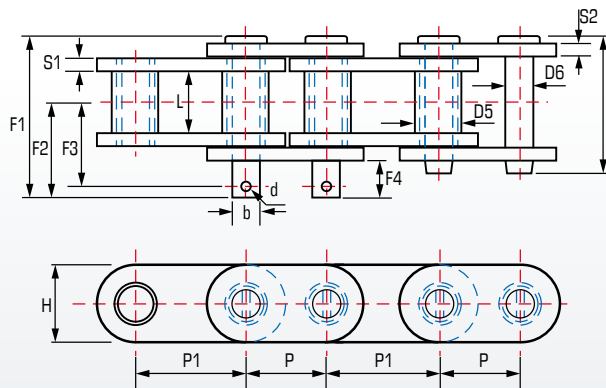

Engineering Class Feeder Breaker Chain

Chain Number	Pitch		Inner Width L	Bush Diameter D5	Plate Height H	Thickness		Pin		F1	F2	F3	b	d	F4	Average Ultimate Strength lbs
	P	P1				Inner Plate S1	Outer Plate S2	Diameter D6	Length F							
	inches															
D5561	3.000	4.000	1.875	1.500	2.500	0.562	0.500	0.995	4.906	5.781	3.500	3.094	0.928	0.360	1.469	168,000
D6569	3.500	-	2.250	1.740	2.750	0.562	0.500	1.113	5.344	6.310	3.841	3.484	1.092	0.358	1.591	160,000
D5671	6.000	-	3.625	2.590	4.500	0.750	0.750	1.750	8.625	9.520	5.620	4.765	1.740	12.700	2.140	420,000

Mining Chains

Buffalo Feeder Breaker Chain

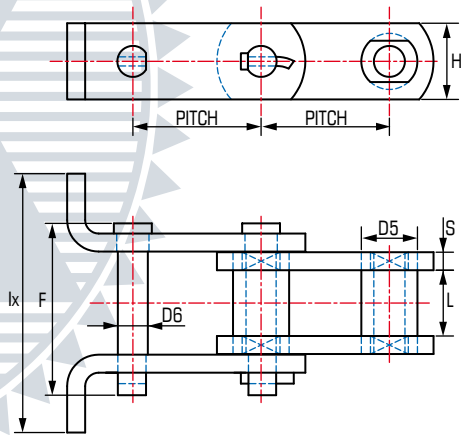

Buffalo Feeder Breaker Chain

Chain Number	Pitch	Inner Width Max	Bush Diameter Max	Plate Height Max	Plate Thickness Max	Pin Diameter Max	Pin Length Max	Lx	Average Ultimate Strength	Rated Working Load	Weight
		L	D5	H	S	D6	F				
inches									lbs		lbs/ft
D3905	4.00	0.938	1.750	2.375	0.560	0.940	5.375	8.000	144,500	16,000	11.18

Road Headers or Dintheaders Chains

Road headers or Dintheaders are a multipurpose mining machine used in such as Heading machines in the advance or retreat of a long wall face development, Dinting (floor grading) of roadways affected by strata disturbance and coal production in short wall operations or room and pillar operations.

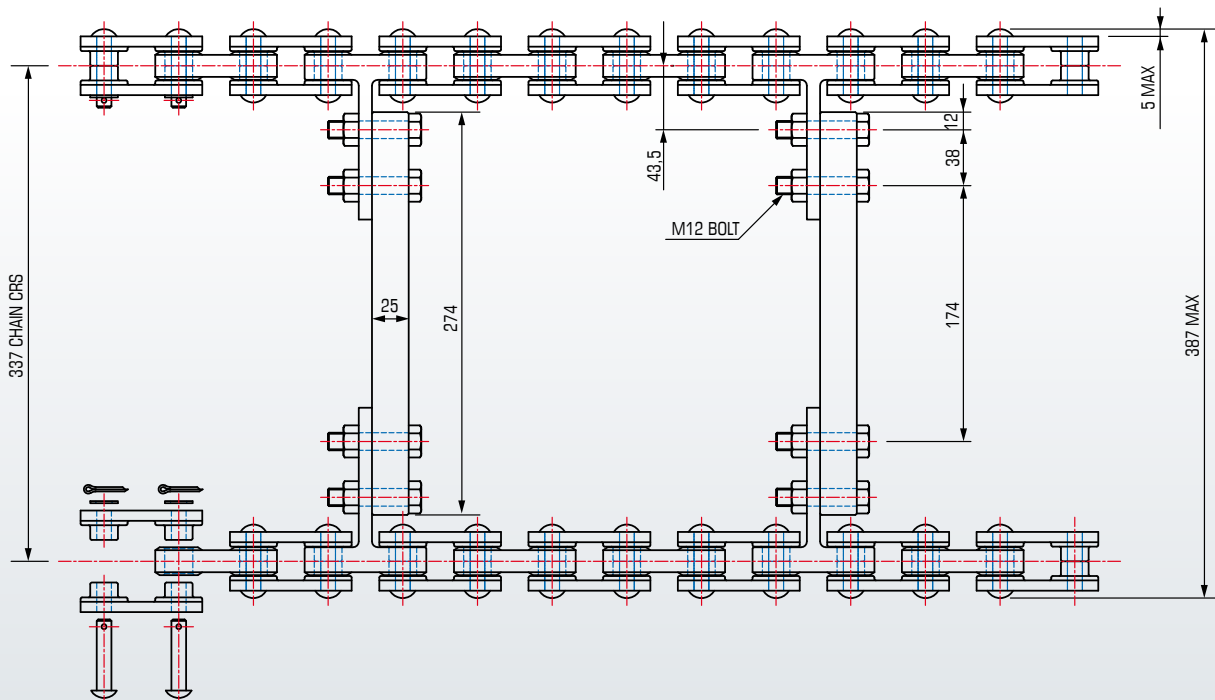

Wash Box Chains Specifications

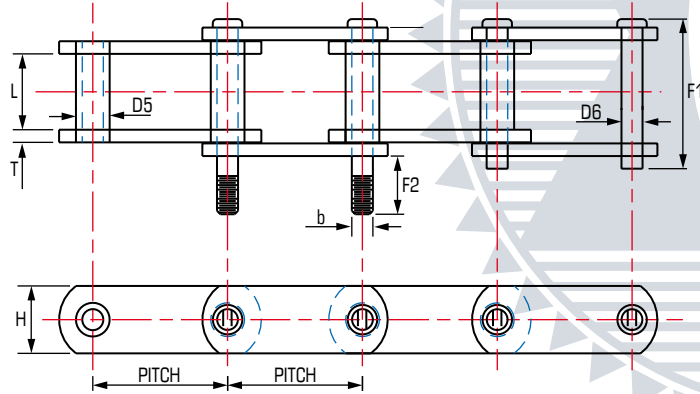

Wash Box Chains Specifications

Chain Number	Pitch inches	Space	Chain Width		Pins		Bushings		Sidedbars			Attachments		Approx. Weight lbs/ft
			Overall	Inside	Diameter	Material	Diameter	Material	Thickness	Height	Material	b	F2	
			F1	L	D6		D5		T	H				
JKM3075H/D3X4	3.075	Ev. 4th	4.00	1.31	0.75	ACHCP	1.25	CCH	0.38	1.75	CHT	0.75	1.25	10.2
JKM3075H/D3X6	3.075	Ev. 6th	4.00	1.31	0.75	ACHCP	1.25	CCH	0.38	1.75	CHT	0.75	1.25	9.8

Drop Forge Rivetless Chain with Extended Pins

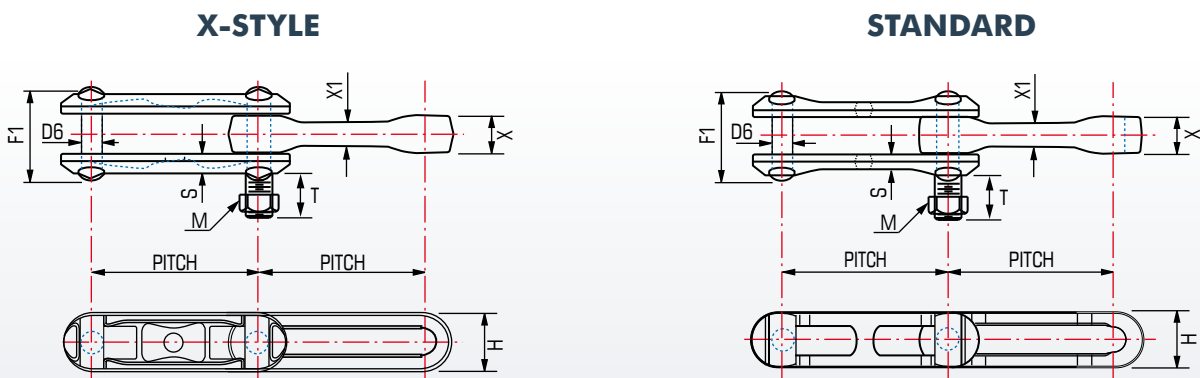

Drop Forge Rivetless Chain with Extended Pins

Chain Number	Pitch	Average Tensile Strength	X1	X	D6	H	S	F1	Attachments			Approx Weight lbs/ft
									Space	T	M	
									inches			
X-678	6.031	85,000	0.81	1.31	0.88	2.00	0.50	3.09	2 Ext. Pins Ev. 4th	1.50	0.75	6.9
698	6.031	130,000	1.00	1.56	1.13	2.52	0.63	3.75	2 Ext. Pins Ev. 4th	1.50	0.75	12.1

Mining Chains

Cardan or Biplaner Chains

Cardan or Biplaner chains are multidirectional as a result of a universal joint at the flight position. They are principally employed in conveying mined minerals at high speeds in tunnelling machines or continuous mining equipment. The chain components are forged from optimum materials and heat treated to ensure maximum performance and reliability in operation.

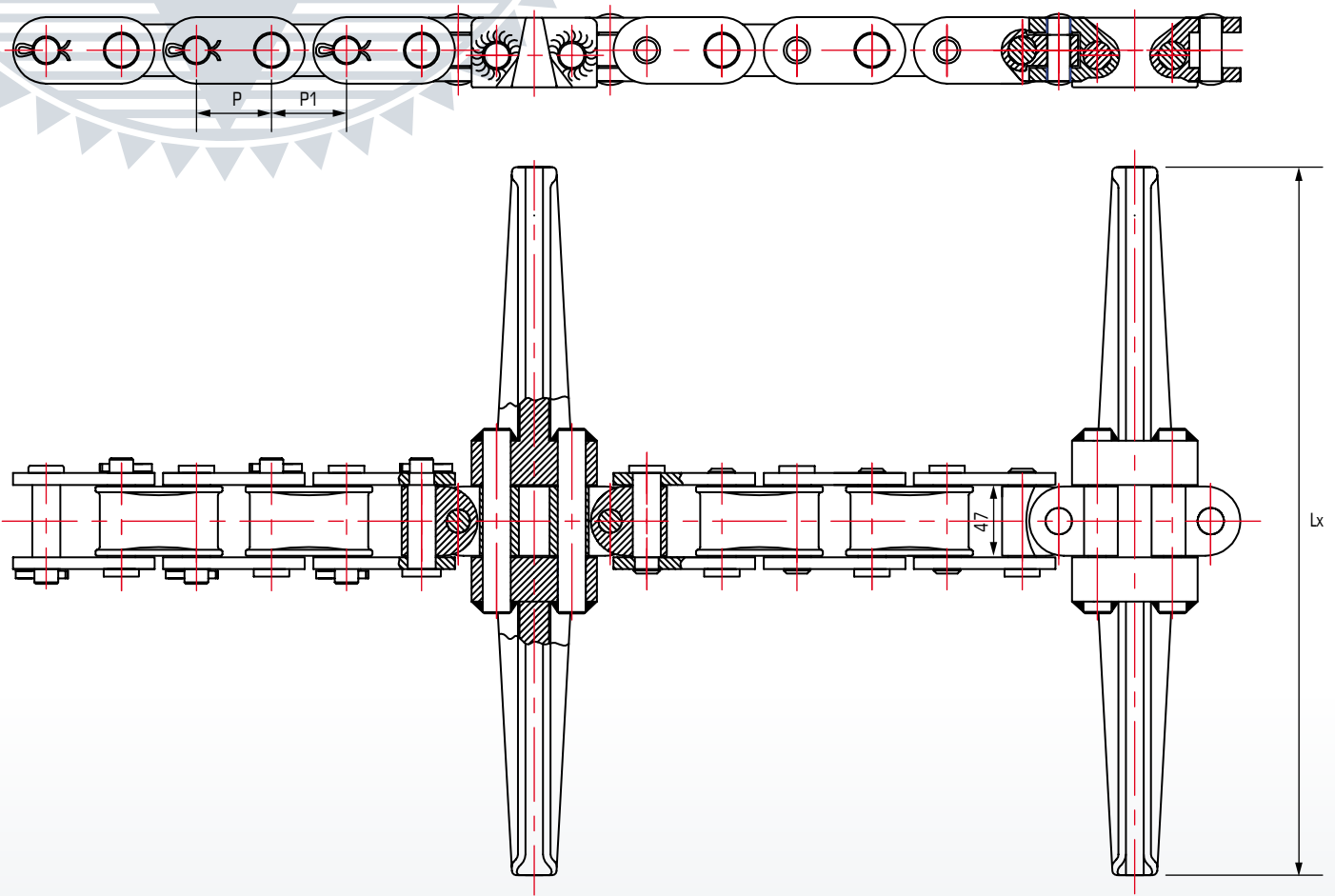

Cardan or Biplaner Chains

P + P1	P	P1	Lx
inches			
4.000	2.000	2.000	18.75
5.250	2.438	2.813	16.05
5.250	2.625	2.625	23.50
5.625	2.625	3.000	27.50

Round Link Steel Chains and accessories

Round link steel chains have become a proven standard in mining and have developed in the coal mining industry along with Long wall mining, a highly effective means of extraction, since the 1960s. Armoured face conveyors require a chain that will run over long distances and offer flexibility in operation. The main standard is covered by DIN 22252.

Round Link Steel Chains

Nominal size d x t	Diameter		Pitch		Width		Gauge Length	
	d	Tolerance	t	Tolerance	Inside b1 min	Outside b2 max	5 x t	Tolerance
14 x 50	14	±0.4	50	±0.5	17	48	250	±1.0
18 x 64	18	±0.5	64	±0.6	21	60	320	±1.0
19 x 64.5	19	±0.6	64.5	±0.6	22	63	322.5	±1.0
22 x 86	22	±0.7	86	±0.9	26	73	430	±1.0
26 x 92	26	±0.8	92	±0.9	30	85	460	±1.0
30 x 108	30	±0.9	108	±1.1	34	97	540	±1.2
34 x 126	34	±1.0	126	±1.3	38	109	630	±1.3

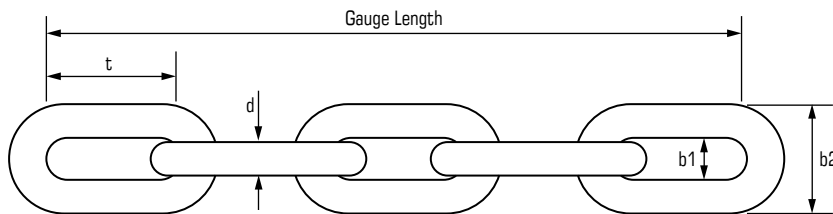

Elongation at test force 1.6% max.
Total elongation at fracture 14% min.
Fatigue test 70,000 cycles min.

Round Link Steel Chains

Nominal size d x t	Reference number TH	Test force Min kN	Breaking force WF DIN Min kN	Operating force WF DIN Max kN	Breaking force WF DIN+ Min kN	Operating force WF DIN+ Max kN	Bend test deflection mm	Weight kg/m
18 x 64	1864TH	305	407	254	460	287	18	±1.0
19 x 64.5	1964TH	340	454	283	510	318	19	±1.0
22 x 86	2286TH	456	608	380	680	425	22	±1.0
26 x 92	2692TH	637	850	531	960	600	26	±1.0
30 x 108	30108TH	848	1130	707	1270	795	30	±1.2
34 x 126	34126TH	1090	1450	907	1640	1026	34	±1.3

Round Link Deep Case Hardened Chains

For use with abrasive material, or where excessive friction occurs case hardened chain may increase operational life considerably over that of standard chains.

Based on DIN 22252:2001 Round link steel chains. Additionally proof loaded and tested.

Round Link Steel Chains

Nominal size d x t	Ref. Number	Pitch nominal	Width		Test force	Breaking force	Weight
			Inside min.	Outside max.			
			mm		min. kN		kg/m
14 x 50 CH	14/50/CH	50	16.5	47	74	128	4.1
16 x 64 CH	18/64/CH	64	20	55	96	160	5.1
19 x 75 CH	19/75/CH	75	22	63	135	225	7.6
22 x 86 CH	22/86/CH	86	26	75	183	304	9.5
26 x 100 CH	26/100/CH	100	31	87	255	425	13.3
30 x 120 CH	30/120/CH	120	36	101	340	566	17.5
34 x 136 CH	34/136/CH	136	39	113	425	710	23.8

Proof Strength 240 N/mm²
Carburizing Depth 0.09d

Breaking Force 400 N/mm²
Hardening Depth 0.05d

Surface Hardness 800HV 40
Material: chrome-Nickel Alloy Steel

All dimensions in mm

Mining Chains

Twin Outboard Chain Systems

Shackle Type Connectors

There is also a range of nuts, bolts and flight bars to suit. Further details can be obtained on request.

Padless Connector

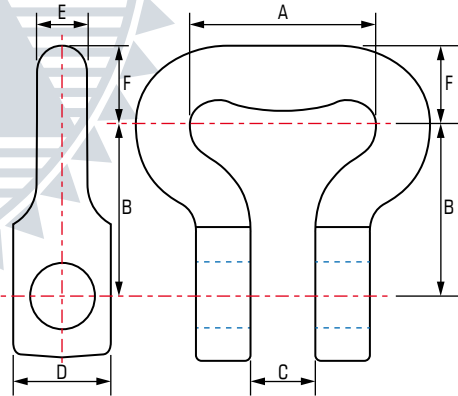

Padless Connector

Chain Number	Ref. Number	A	B	C	D	E	F	Weight kg
		max mm						
14 x 50	40/14	50	47.5	17	28	15	23	0.46
18 x 64	40/18	64	55	22	38	19	30	1
22 x 86	40/22	86	75	31	50	23	38	1.6
30 x 108	40/32	108	96	34	64	31	50	4

Connector with Wear Pad

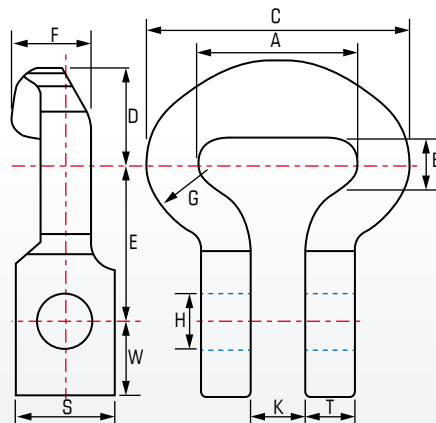

Connector with Wear Pad

To suit nominal chain size mm	Ref. Number	Test force	Elongation at Test force	Breaking force	Elongation at break	A	B	C	D	E	F	G	H	K	S	T	W	Weight kg/m
		min.-kN	% max	min.-kN	% min	mm												
14 x 50	40/14/WP	180	2	225	8	50	15	81	29	48	30	23	17	18	30	13	18	0.5
18 x 64	40/18/WP	325	2	405	8	64	20	108	44	55	40	31	21	19.5	43	19	40	1.38
19 x 64.5	40/19/WP	325	2	405	8	64.5	20	105	44	55	40	31	21	19.5	43	19	40	1.38
22 x 86	40/22/WP	440	2	550	8	86	24	134	58.5	75	46	37	25	24	52	22	44	2.58

BC Bucket Clamps

Special bucket attachments are available for the CH series chain to be used on vertical bucket elevators. They are designed to operate with friction drives and tooth sprocket wheels. The bracket allows continuous strands to be employed and operational reliability is increased as they are not an integral part of the haulage member simply an addition. Clamps can be reused when base chain is worn.

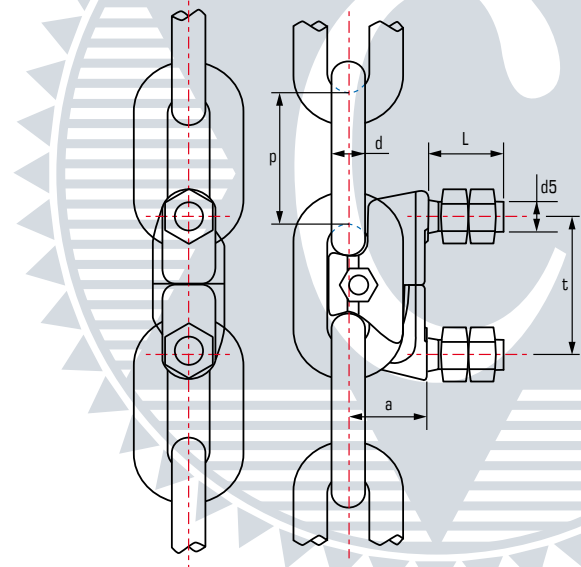

BC Bucket Clamps

Clamp Reference Number	Chain Ref. Number	t	p	d	a	L	d5	Weight kg/pc
		mm						
BC16	16 x 64 CH	63	64	16	37	40	M16	0.75
BC19	19 x 75 CH	80	75	19	47	50	M20	1.3
BC22	22 x 86 CH	91	86	22	52	55	M24	2.2
BC26	26 x 100 CH	105	100	26	57	58	M24	2.6
BC30	30 x 120 CH	126	120	30	71	65	M30	4.5
BC34	34 x 136 CH	147	136	34	81	75	M36	7.1

CC Series Chain Connector

A new generation chain connector is available with the CC series clamp. It is suitable for both horizontal and vertical application to be used in AFC, plough haulage and general conveying applications. Special material selection combined with close tolerance machining ensures the connector offers high strength greater than the minimum demands of DIN 22252/2.

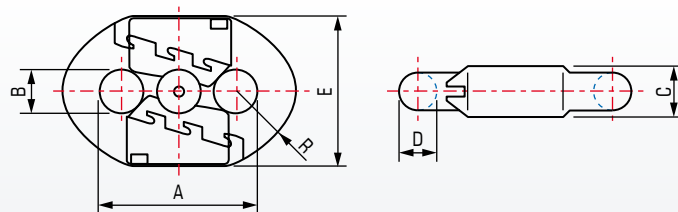

CC Series Chain Connector

For nominal chain size mm	Reference Number	D	A	B	E	C	R	Test force TF	Breaking force BF kN	Operating force WF	Weight kg/pc
		Max	Max	Max	Max	Max	nom				
14 x 50	47/CC14	14±0.5	50±0.8	16	51	19	27	185	246	154	0.80
18 x 64	47/CC18	18±0.5	64±0.8	20	65	23	31	305	407	254	1.32
22 x 86	47/CC22	22±0.7	86±0.9	24	85	27	35	455	645	380	1.35
26 x 92	47/CC26	26±0.8	92±0.9	28	97	33	41	637	900	531	1.92
30 x 108	47/CC30	30±0.9	108±1.1	32	109	36	47	848	1200	707	2.98
34 x 126	47/CC34	34±1.0	126±1.3	36	121	41	52	1090	1540	907	4.15



JOHN KING

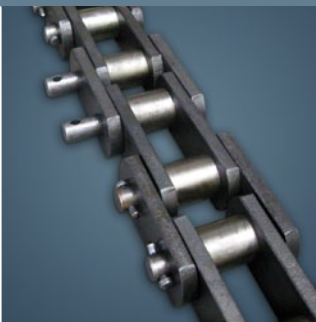

John King Chains Limited

New Climax Works,
Lancaster Business Park,
Sherburn-in-Elmet LS25 6NS UK
Tel: (44) 1977 681 910
Fax: (44) 1977 681 899
Email: general@johnkingchains.co.uk

John King Chains (SA) (PTY) Ltd.

No. 17 N12 Airport Industrial Park,
Dr. Vosloo Road, Barletts, Boksburg,
Johannesburg
Tel: (27) 11 894 3570
Fax: (27) 11 894 3501
Email: sales@jkc.co.za

John King Chains (Central Europe)

ul. Grunwaldzka 182
85-401 Bydgoszcz, Poland
Tel/Fax: (48) 52 349 08 97
Mobile: (48) 600 871 077
Email: aw@johnkingchains.com

John King USA Inc.

200 Catherine Street, Unit 7, Box 8,
East Peoria, USA IL 61611
Tel: (1) 309 698 9250
Fax: (1) 309 698 9259
Email: sales@johnkingchains.com

Cadenas John King Ltda.

Panamericana 5 Sur Km. 34
Parcela 13 – Lote C
Buin – Santiago, Chile
Fonos: (56) 2517 7313
Email: manuel@johnkingchains.com



REG NO: FM77342

www.johnkingchains.com